



Questions? Call Rolltec®
at 1-800-667-0474

Installation Instructions for the Rolltec® Adalia X3M™ Awning

Table of Contents

Available installation brackets	2
Side dimensions of various installations	3
Determining installation height and coverage	4
Positioning installation brackets	5
Mounting wall brackets to surface	6
Attaching and operating the awning	7
Installation of the protective hood (optional)	8
Slope adjustment instructions	9

General Tool Requirements

- Measuring tape
- Hammer
- Hammer drill
- Masonry bit set*
- Wrench and ratchet set (3/4", 1/2", and 13mm sockets)
- 3/16" and 5mm Allen keys
- Two ladders (depending on awning width)
- Phillips driver #2
- Level
- Chalk
- Extension cord

* 3/16" steel bit if required for pilot holes

Supplied: Installation wall brackets. Other brackets available upon request.

Not Supplied: Anchors, lag bolts, or mounting screws for installation. We recommend 3/8" lag bolts with washers and corresponding anchors.

Notes

It is extremely important to take into consideration the type of building surface when mounting a lateral arm awning. Whether the building's exterior is stucco, brick, or wood shingles, it is important to install the mounting brackets in a proper manner, to properly secure the awning to the building's surface.

A retractable fabric awning is designed to provide **shade** and light rain protection[†], and should be retracted during heavy rain, snow, or severe wind conditions[‡].

[†] Minimum of 15° slope is required, and should be used under proper care.

[‡] See warranty.

Available Installation Brackets for the Adalia X3M™

Wall Bracket

Extruded aluminum with a powder coated finish. For flat surface mounting, such as brick, wood, or siding.

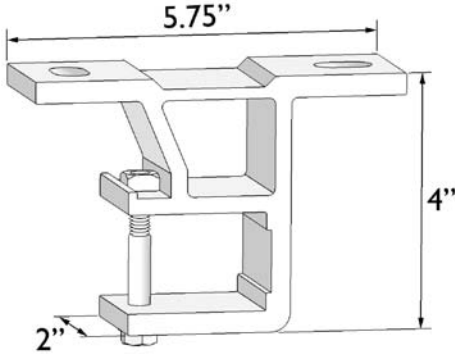
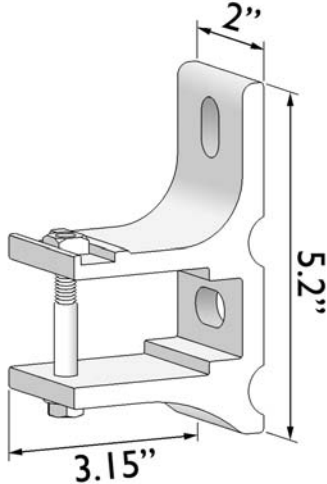

Ceiling Bracket (optional)

To be used for installations under the soffit. Can be used by themselves, or in combination with rafter brackets.

Rafter Bracket (used in combination with ceiling brackets, optional)

Rafter brackets are made of galvanized steel with a white powder coated finish. They are available in 4 sizes, and must be used in combination with a ceiling bracket.

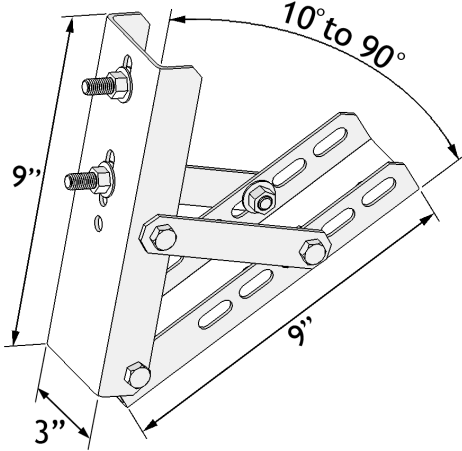
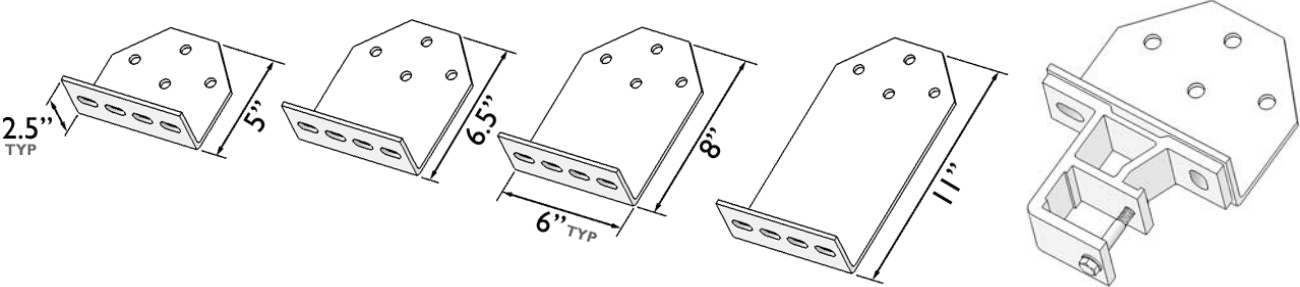

Roof Bracket

Stainless steel, used in combination with a wall bracket when installing on a roofline.

Roof brackets can be adjusted between 10° and 90° to accommodate the slope of the roof.

Side Dimensions for Various Installations

Installation on wall

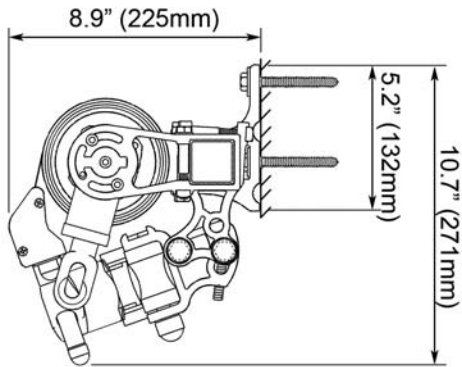

Installation on Wall with Optional Protective Hood

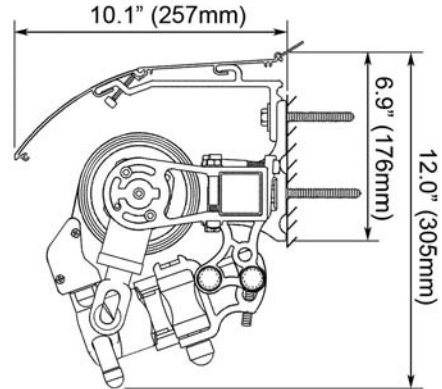

Installation under overhang

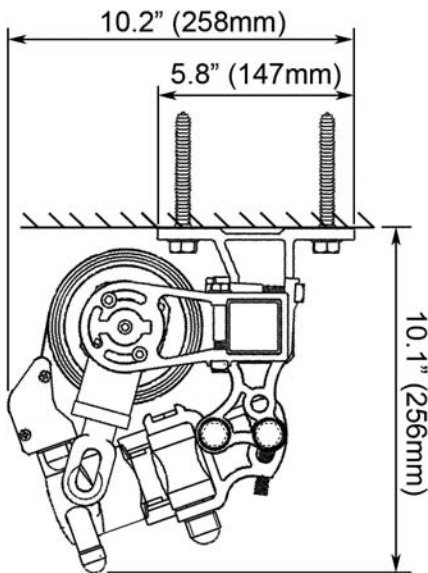

When mounting onto a rafter under a soffit, make sure that the back edge of the bracket is at least 10" from the front edge of the roof. This protects the retracted awning from weather elements.

Bolt only 3 holes of the rafter bracket to the center of the roof truss, the wood might crack if all 4 holes are bolted.

Installation with rafter brackets

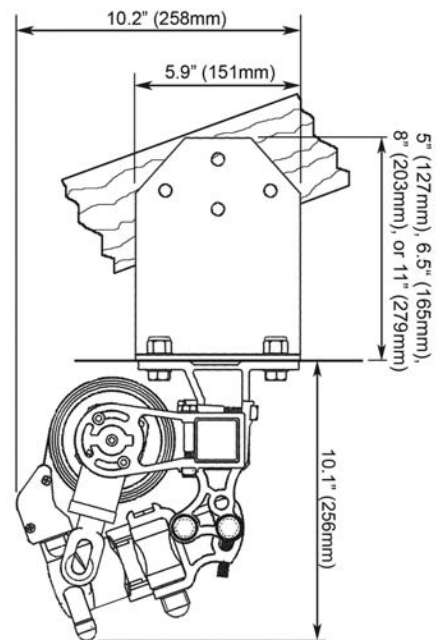

Installation on roof with protective cover

The angle of the roof brackets is adjusted between 10° and 90° to make sure that the awning is mounted upright despite the slope of the roof. A protective hood is recommended.

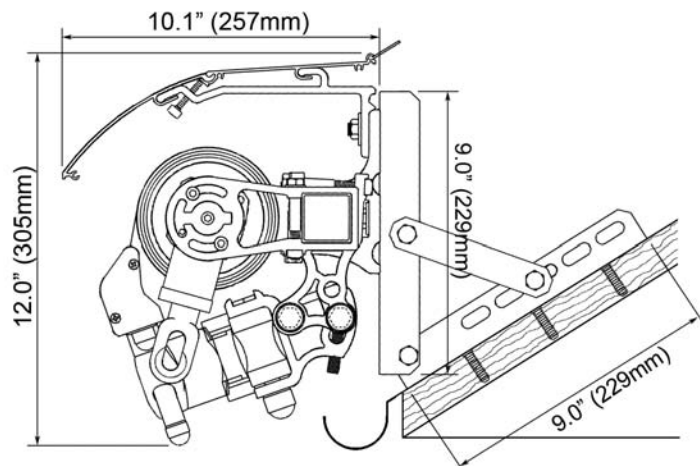

Determining Installation Height and Coverage

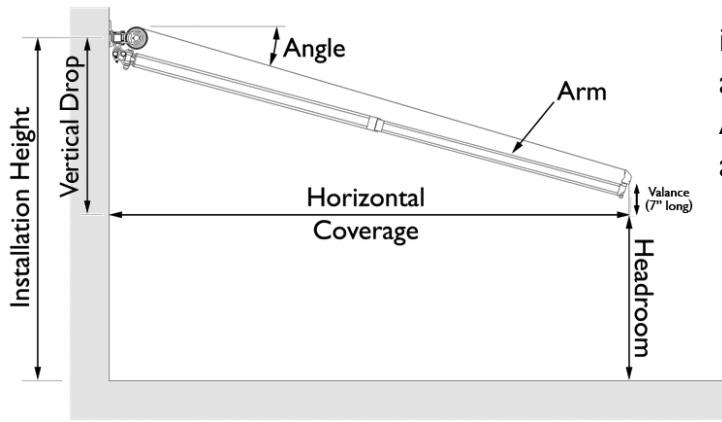

The horizontal coverage of an awning is determined by the length of the arms and the angle of the awning. Arms come in several standard sizes, and the angle can be finely adjusted.

Horizontal Coverage	Angle			
	5°	10°	15°	20°
5'4"	5' 4"	5' 3"	5' 2"	5'
6'9"	6' 8"	6' 7"	6' 6"	6' 4"
8'8"	8' 7"	8' 6"	8' 4"	8' 2"
10'	9' 11"	9' 10"	9' 8"	9' 5"
11'8"	11' 6"	11' 5"	11' 3"	11'

NOTE: To be used for light rain protection, an awning must be installed with at least a 15° slope.

Tables for Various Arm Sizes and Angles

Suggested Installation Height	Angle			
	5°	10°	15°	20°
5'4"	8' 1"	8' 7"	9'	9' 5"
6'9"	8' 2"	8' 9"	9' 4"	9' 11"
8'8"	8' 4"	9' 1"	9' 10"	10' 7"
10'	8' 5"	9' 4"	10' 2"	11'
11'8"	8' 7"	9' 7"	10' 7"	11' 7"

Vertical Drop	Angle			
	5°	10°	15°	20°
5'4"	1' 1"	1' 7"	2'	2' 5"
6'9"	1' 2"	1' 9"	2' 4"	2' 11"
8'8"	1' 4"	2' 1"	2' 10"	3' 7"
10'	1' 5"	2' 4"	3' 2"	4'
11'8"	1' 7"	2' 7"	3' 7"	4' 7"

NOTE: The table of suggested installation heights uses 7' of headroom below the front valance. To calculate installation height for a different amount of headroom, use the table of vertical drops, and add to your preferred headroom:

$$\text{HEADROOM} + \text{VERTICAL DROP} = \text{INSTALLATION HEIGHT}$$

Brackets in Relation to Awning Width

Number of Installation Brackets	Awning Width					
	7'-10'	11'-13'	14'-15'	16'-18'	19'-23'	24'
Arm Size 5'4"-10'	2	3	3	4	5	6
Arm Size 11'8"	n/a	n/a	4	4	5	6

Awnings wider than 20' require 3 arms.

Positioning Installation Brackets

Fig. 1: Awning with 2 Arms and 2 or 3 Brackets

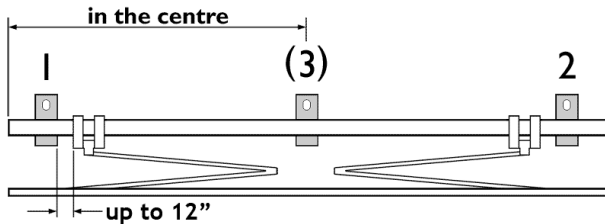

Refer to these illustrations when determining the positions of installation brackets. See the next page for step-by-step installation instructions.

Fig. 2: Awning with 2 Arms and 4 or 5 Brackets

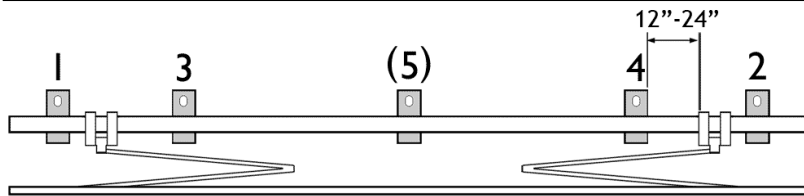

Brackets that are placed on the outside of the arm shoulder (bracket 1 and 2 in all the illustrations) should be as close to the arm shoulder as possible, up to 12".

Fig. 3: Awning with 3 Arms and 5 Brackets

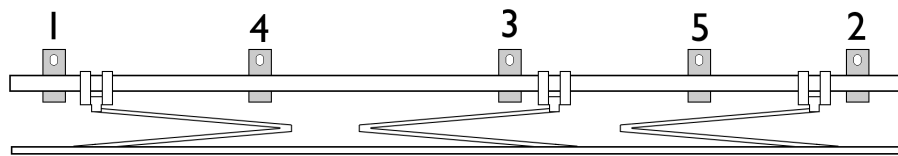

Brackets placed inside the arm shoulder (bracket 3 or 4 in Fig. 2) should be 12" to 24" from the arm shoulder.

Fig. 4: Awning with 3 Arms and 6 Brackets

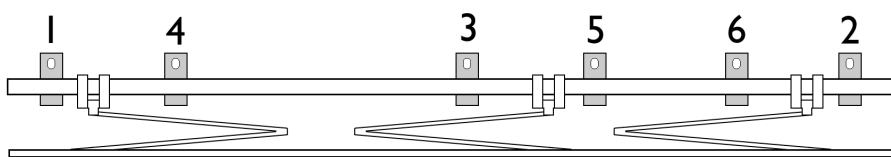

NOTE 1: There should be a bracket on the outside of the shoulder whenever possible!

Fig. 5: Awning with 4 Arms and 8 Brackets

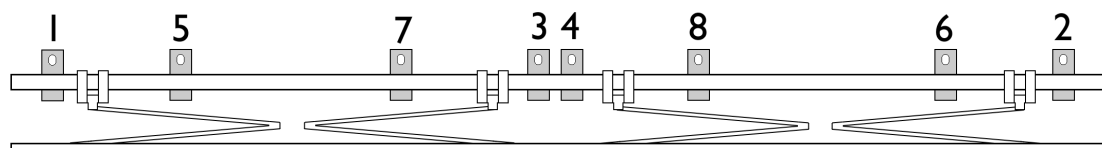

NOTE 2: Wider awnings come with a fabric centre support. It should be taken into consideration when positioning brackets.

It is important to properly secure installation brackets to the surface. Due to the weight of the awning, added pulling forces and aerodynamic lifts when the awning is extended, it causes considerable stress on the installation brackets.

Expected stress values are factored into the number of brackets shipped with an awning. However, it is assumed that the awning will be installed on a solid surface such as a brick wall. When installing on a weaker surface, it is recommended to use additional brackets and reinforce the surface to spread the load. Extra brackets are available on request, for a small added charge.

Mounting Wall Brackets to Surface

NOTE: Check to see that the wall is flat and even. If it is **not**, it is advisable to mount the brackets on a wooden (cedar, or plastic wood) board first. The brackets can be attached to the board with carriage bolts, before the board is mounted on the wall. Use a 2"x8" board; if using a protective hood use a 2"x10".

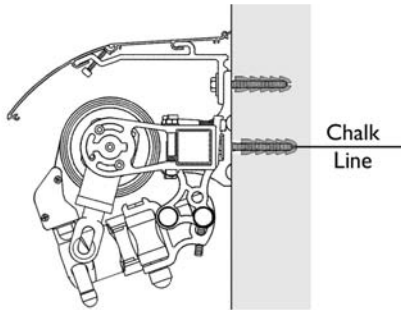

Step 1. Draw a Horizontal Line

This step is not necessary if installing on brick. Chalk a horizontal line at the optimum installation height (as determined on page 4). The level of the line corresponds to the level of the bottom installation screw.

Step 2. Mark Where to Drill Holes

Align a wall bracket so that the chalk line goes through the middle of the bottom hole (A). If installing on brick, make sure that both holes are on brick and not mortar (fastening an awning to mortar will cause it to loosen over time).

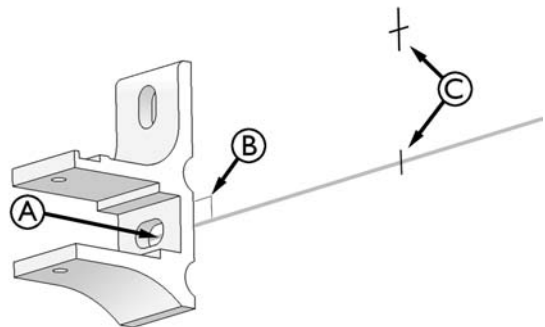

Use a level to make sure that the bracket is upright (B).

Use a pencil to draw a line down the middle of the little area of wall that is visible through the bottom hole. Keeping the bracket in place, draw a pair of perpendicular lines that intersect in the centre of the top hole. (C) illustrates the resulting marks.

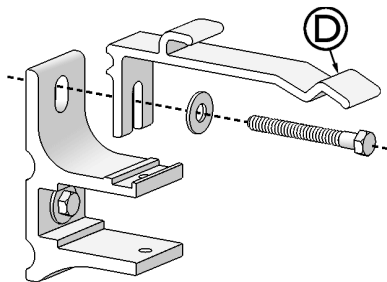

Step 3. Drill Holes and Attach Outside Brackets

After marking the locations of drill holes for the two outside brackets, drill the holes and attach them loosely.

NOTE: If a protective hood is to be used, the hood brackets should be installed together with the wall brackets (D).

Step 4. Align and Attach Remaining Brackets

Align the remaining wall brackets with respect to the two outside ones. They will need to be able to fit and support a square metal bar, and good alignment is important.

Once you are satisfied with the alignment, tighten all screws firmly and check that each bracket is attached solidly to the surface.

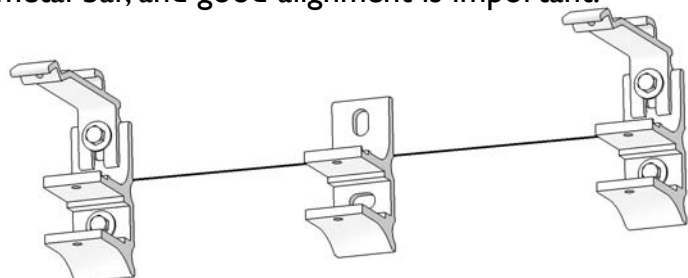

Attaching and Operating the Awning

Attaching the Awning

1. Make sure both your hands and the working area are clean.
2. Remove the awning from the protective sleeve.
Do not use a knife, as you risk damaging the fabric.
3. Slide the square bar of the awning into the mounted brackets. Use a 13mm ratchet and the supplied bolts to secure the square bar inside the brackets.

The procedure is identical for both wall and ceiling installations.

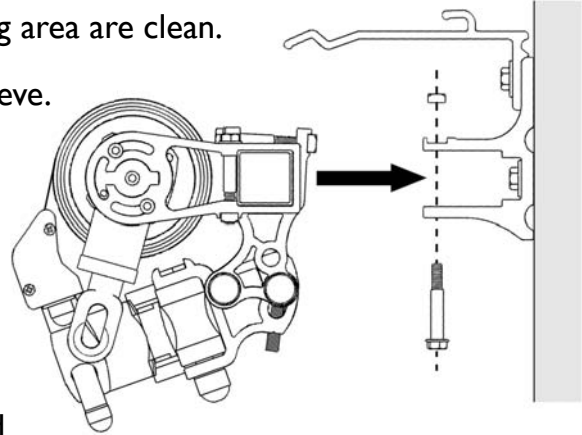

Extending and Retracting the Awning

Manual Operation

First off, attach the crank by hooking it through the loop in the gear mechanism, as shown.

For a **right side** crank (pictured), turning the crank counter-clockwise will extend the awning, and turning clockwise will retract it. For a left side crank, it's the other way around.

You will know that the awning has fully extended once the fabric becomes slightly slack. When this happens, turn the crank in the opposite direction just enough for the fabric to go back to being taut.

When retracting from a fully extended position, the first turn or two can offer a fair amount of physical resistance. This is normal, and should not cause alarm.

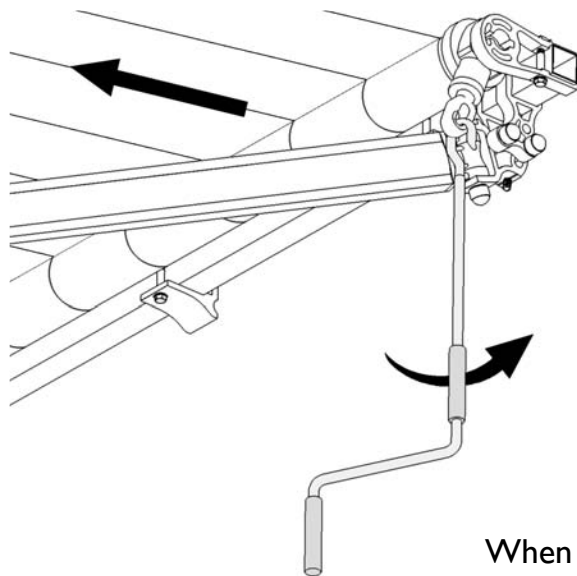

Motorized Operation

Use the supplied electrical 3-way control (switch or remote) to operate your awning. The middle button lets you stop the awning partway. If you adjust the slope, you might have to adjust the limit switches on your motor. Please see the instructions supplied with the motor.

Installation of the Protective Hood (Optional)

Structure of a Protective Hood

The hood is manufactured in two pieces: a female part, and a male part. The female part holds a PVC weather strip. This strip goes against the wall, eliminating the need for caulking.

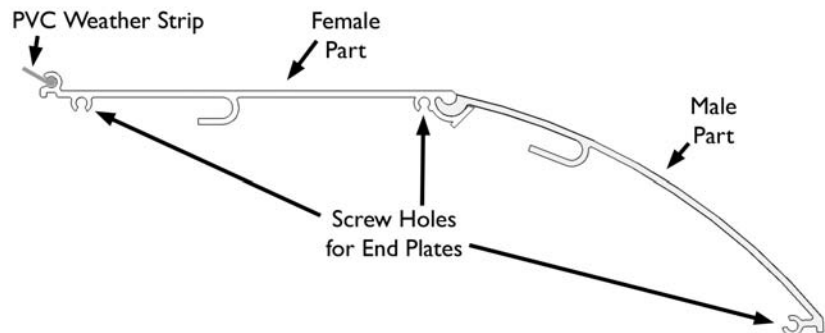

The two parts fit together as shown, and hold together mainly with gravity. The three small grooves in the hood are screw holes, and are used in attaching side cover plates. The remaining two grooves (which are significantly larger), are used to fit the hood onto hood brackets.

Hood brackets are usually installed at the same time as wall brackets (see page 6, Fig. D), but can be added later. Remember that hood brackets must go in front of the wall brackets, but behind the washers of the screws securing the awning to the wall.

NOTE: A protective hood is optional, but it comes highly recommended when the awning is installed on a flat, exposed surface. If the awning is equipped with an electric motor and there is no overhang shielding the awning from the elements, a hood is mandatory. A hood cannot be used in conjunction with ceiling brackets.

Fitting a Hood onto Hood Brackets

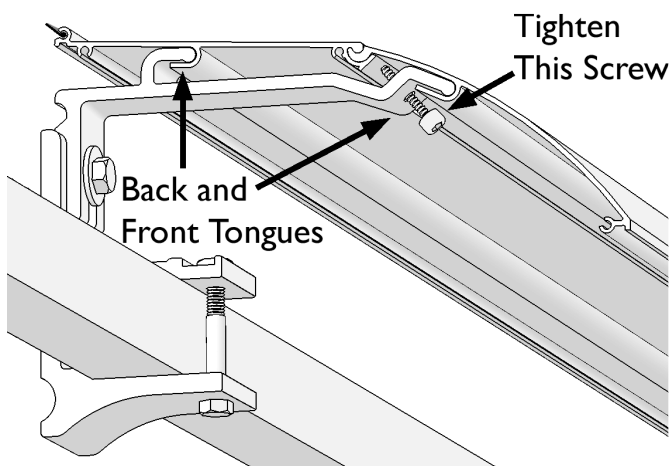

Each hood bracket comes with two tongues that fit into the large grooves on the underside of the protective hood. The hood is slid on after the brackets have been installed.

Afterwards, the screw shown in the picture on the left should be tightened.

NOTE: A protective hood can be installed before or after mounting the awning onto the wall brackets.

Slope Adjustment Instructions

Preparation

- You need a 3/16" Allen key and a 3/4" wrench-and-ratchet set to perform the adjustment procedure.
- Before starting, extend the awning fully.
- Note that slope adjustment is done on one arm at a time, the arms should not differ in slope by more than 10° (you need to go back and forth between arms if you want a steeper adjustment), and the final slope of each arm must be equal.
- You should support the arm being adjusted.

Procedure (for each arm)

1. Locate two side bolts on the arm shoulder.
2. Remove the two plastic end caps covering the back bolt (see A; second cap on other side of shoulder).
3. Using the 3/4" wrench and ratchet, loosen (but do not remove: max. 1.5 turns!) the back bolt (see B).
4. Lift the arm from the bottom, to alleviate the pressure from the shoulder, before turning the adjustment screw.
5. Use the 3/16" Allen key to turn the adjustment screw (see C), located on the bottom of the arm shoulder. Turning clockwise raises the angle, while turning counter-clockwise lowers it.
6. Once the arm is at the desired slope, retighten the back bolt and put the plastic end caps back on.

